

# Standard Series LFP12100A 12V100Ah

**FirstPower®**

## Dimension

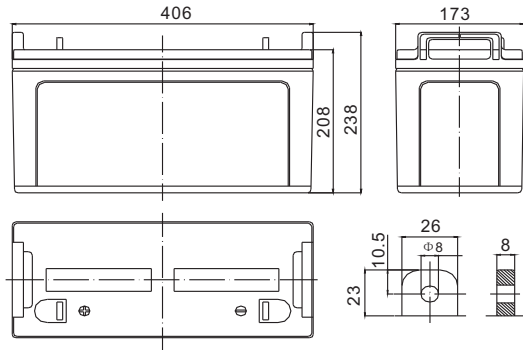

## Specification

Nominal Voltage		12 V
Capacity(10HR, 25°C)		100 Ah
Dimension	Length	406mm (16.0inch)
	Width	173mm (6.8inch)
	Height	208mm (8.2inch)
	Total Height	238mm (9.4inch)
Approx. Weight		31.5kg (69.5lbs)

## Characteristics

Capacity 20°C (68°F) To 1.70V/Cell	20 hour rate	104.6Ah
	10 hour rate	100Ah
	5 hour rate	90Ah
	1 hour rate	60.5Ah
	15 min rate	38.5Ah
Internal resistance(Fully charged, 25°C)		Approx.4.5m Ω
Capacity affected by temperature (10HR)	40°C	102%
	25°C	100%
	0°C	85%
	-15°C	65%
Self-discharge (25°C)	3 month	Remaining Capacity: 91%
	6 month	Remaining Capacity: 82%
	12 month	Remaining Capacity: 65%
Nominal operating temperature		25°C ±3°C(77°F ±5°F)
Operating temperature range		-15°C~50°C(5°F~122°F)
Float charging voltage(25°C)		13.50 to 13.80V
Cyclic charging voltage(25°C)		14.50 to 14.90V
Maximum charging current		30A
Terminal material		Copper
Maximum discharge current		800A(5 Sec.)

## The Relationship for Open Circuit Voltage and Residual Capacity (25°C)

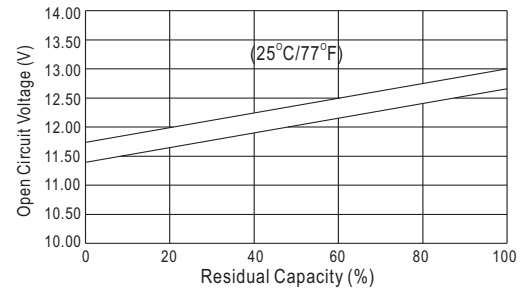

## Charging Characteristics(25°C)

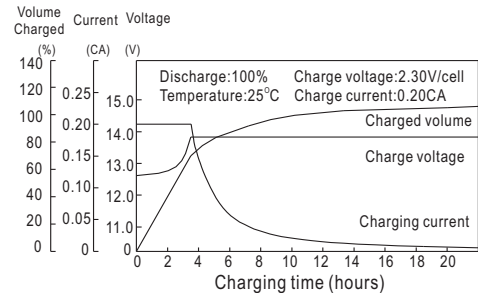

## Cycle Life(25°C)

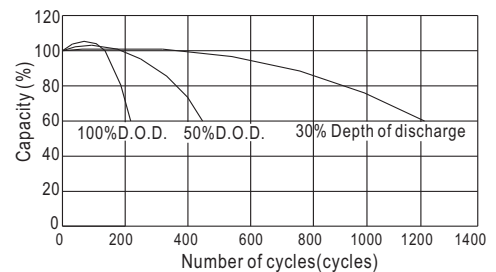

## Constant Current Discharge Characteristics (A, 25°C)

F.V/TIME	5min	10min	15min	30min	60min	3h	5h	10h	20h
9.60V	300	205	160	105	63.0	25.4	18.3	10.2	5.28
10.2V	285	195	154	101	60.5	25.0	18.0	10.1	5.23
10.8V	268	183	146	96.0	57.5	24.5	17.6	10.0	5.20

## Constant Power Discharge Characteristics (Watt, 25°C)

	5min	10min	15min	30min	60min	3h	5h	10h	20h
3150	2214	1757	1178	718	298	216	121	63.3	
2993	2103	1687	1131	689	294	213	120	62.8	
2813	1977	1602	1074	655	288	209	120	62.4	