

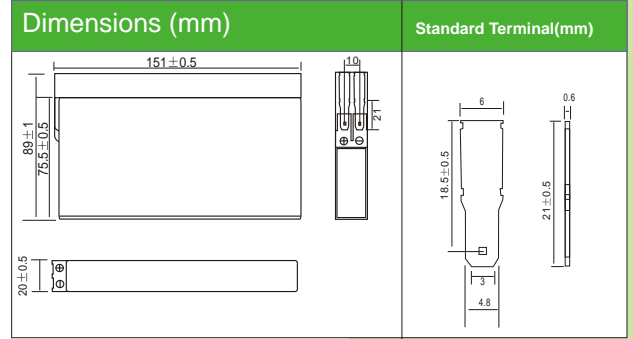

# DJW12-2NP(12V2.0AH)



Physical Specification		
Nominal Voltage		12V
Nominal Capacity (20HR)		2.0AH
Dimension	Length	151 ± 1mm (5.94 inches)
	Width	20 ± 1mm (0.79 inches)
	Container Height	89 ± 1mm (3.50 inches)
	Total Height (with Cover)	89 ± 1mm (3.50 inches)
Weight		Approx 0.68 kg (1.50 lbs)
Standard Terminal		/

## Discharging Current & Discharge Duration Time

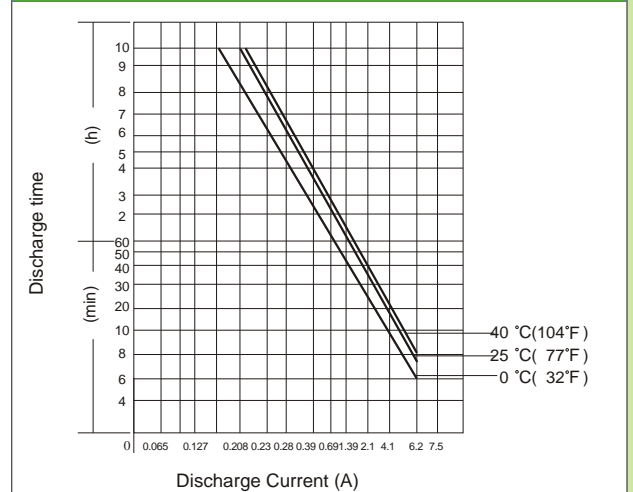

Electrical Specification					
Rated Capacity	20 hour rate (0.10 A)	2.0AH	Constant-Voltage	Cycle	Initial Charging Current less than 0.6A. Voltage 14.4V~15.0V at 25°C (77°F) Temp. Coefficient -30mV/°C
	10 hour rate (0.19A)	1.9AH			
	5 hour rate (0.34A)	1.7AH			
	1 hour rate (1.24 A)	1.24AH			
Capacity affected by Temperature	15minute rate (3.92A)	0.98AH	Charge	Standby	No limit on Initial Charging Current Voltage 13.5V~13.8V at 25°C (77°F) Temp. Coefficient -20mV/°C
	40°C (104F)	103%			
	25°C (77F)	100%			
	0°C (32F)	86%			

## Discharge Characteristics (25°C, 77°F)

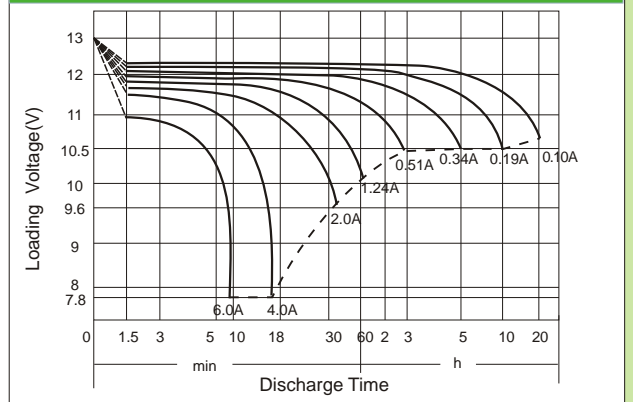

## Constant Current (Amp) and Constant Power (Watt) Discharge Table (25°C, 77°F)

Time(minute) Final voltage/Cell	5	10	15	20	30	45	60	120	180	300	600	1200
	Amp/Watt/Cell	1.3	1.3	1.3	1.3	1.6	1.6	1.67	1.7	1.75	1.75	1.8
A	8.00	5.70	3.92	3.20	2.30	1.60	1.24	0.70	0.51	0.34	0.19	0.10
W	14.32	10.72	7.46	6.26	4.52	3.18	2.46	1.39	1.01	0.68	0.37	0.20