



Valve Regulated Lead-Acid Rechargeable Battery



BPL7-12

The battery is constructed by plates, separators, safety valves and container. Since the electrolyte is held by a glass-mat separator and plates, the battery can be used in any direction and position without leakage.

PERFORMANCE SPECIFICATIONS

Nominal Voltage(V).....	12 volts(6cells in series)
Nominal Capacity(AH)	
20 Hour rate F.V.(1.75V/cell) (350mA to 10.50volts)	7.0A.H.
10 Hour rate F.V.(1.75V/cell) (665mA to 10.50volts)	6.65A.H.
5 Hour rate F.V.(1.75V/cell) (1190mA to 10.50volts)	5.95A.H.
30 Min rate F.V.(1.30V/cell) (7000mA to 7.80volts).....	3.50A.H.
Approximate Weight.....	2600g(5.73lbs.)
Terminal	
Standard.....	Type T2
Optional.....	Type T1
Internal Resistance (Fully Charged Battery).....	<25m Ω
Maximum Discharge Current For 5 sec.(A).....	105A
Maximum Charge Current(A).....	2.1A
Ambient Temperature	
Charge.....	0°C(32°F)~40°C(104°F)
Discharge.....	-20°C(-4°F)~50°C(122°F)
Storage.....	-20°C(-4°F)~40°C(104°F)
Vibration test:	
Frequency: 16.7HZ	
Amplitude: 4mm	
vibrate the battery horizontally or vertically for 60 minutes. The battery have no abnormality.	
Design Life:10 years for standby use at 20°C	
Case.....	ABS
Dimension(mm/inch)	
Length ±1.5mm.....	151/5.94
Width ±1.5mm.....	65/2.56
Container Height ±1.5mm.....	93/3.66
Total Height ±2mm.....	98/3.86
Application.....	Laboratory Equipment, Toy-Cars, Power Packs, Fishing Lights.

BPL7-12 Battery discharge characteristics (25 °C/77 °F)

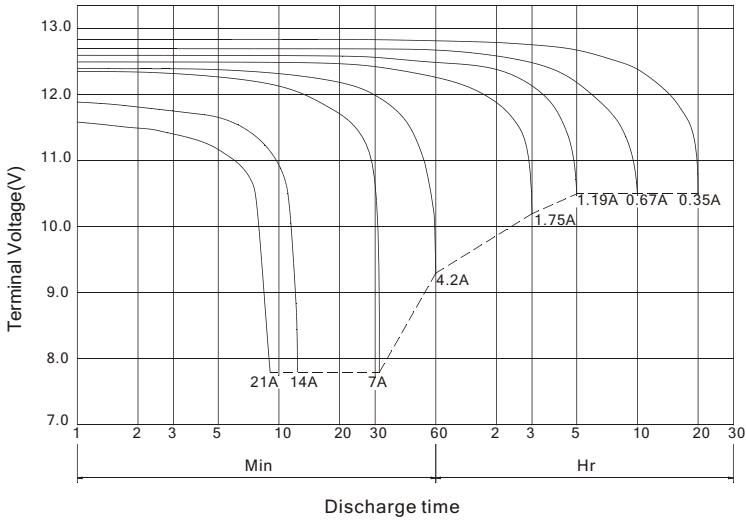

Battery Charging Characteristics

(Typical example of charge characteristic for the standby use)

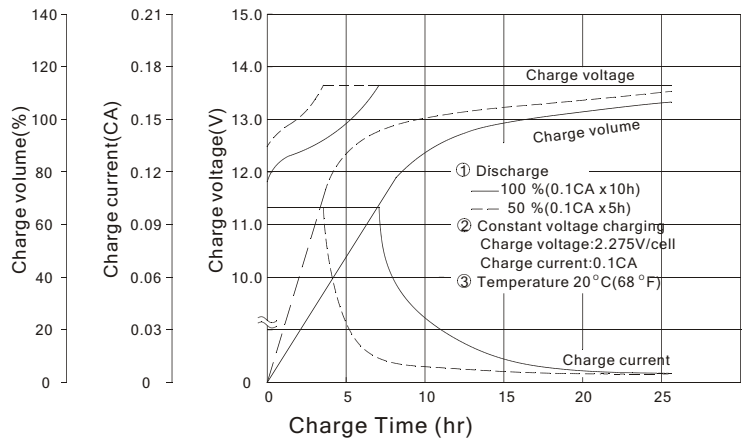

Charging Procedure

Application	Charging method	Charging Voltage at 20 °C (V/cell)	Temperature compensation coefficient of charging voltage (mV/°C/cell)	Max. charging current (CA)	Charging time 0.1CA, 20 °C (h)		Temp (°C)
					100% discharge	50% discharge	
For standby power Source	Constant voltage & Constant current charging (with current restriction)	2.25~2.30	-3	0.3	24	20	0~40 (32~104°F)
For cycle service					16	10	

*Temperature compensation of charging voltage is not needed, when using the batteries within 5 °C to 35 °C range.

Battery Life Characteristics of Cyclic Use

Testing Conditions : Discharge Current : 0.25C Amp (F.V. 1.7V/cell)
Charging Current : 0.1C Amp
Charging Volume : 120% of Discharge Capacity
Ambient Temperature : 20 °C (68 °F)

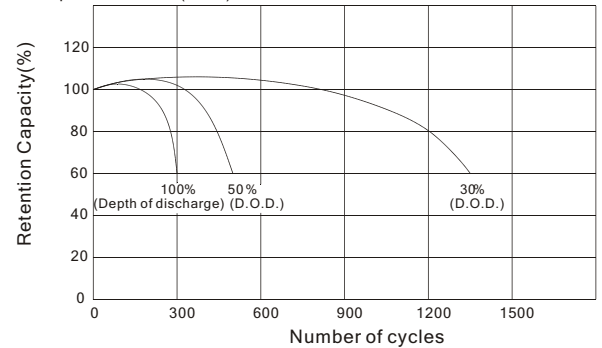

TERMINAL TYPE

mm (inch)

OUTER DIMENSIONS

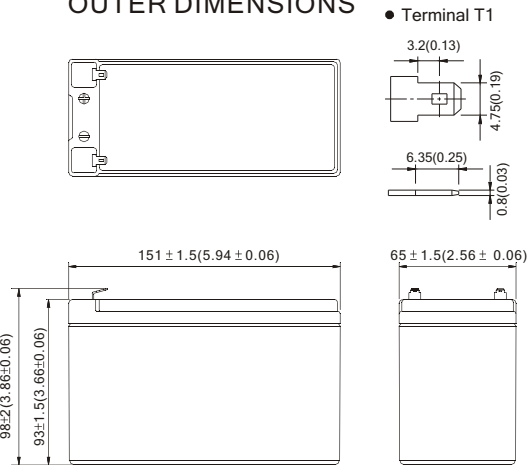

Constant power discharge characteristics at 28°C/77°F

Final Voltage	Discharge time								
	5Min	10Min	15Min	30Min	1Hr	3Hr	5Hr	10Hr	20Hr
10.80V	228	171.4	138.8	83.5	48.4	20.4	14.1	7.86	4.11
10.50V	264	185.7	145.3	86.7	49.8	20.8	14.3	7.98	4.20
10.20V	280	192.4	149.7	88.6	50.7	21.0	14.4	8.02	4.22
9.90V	293	197.0	153.2	89.9	51.4	21.2	14.5	8.04	4.23
9.60V	302	200.9	156.2	90.8	51.9	21.3	14.5	8.04	4.23

TERMINAL POSITION

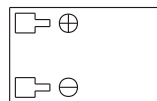

B.B. BATTERY CO., LTD.

Web Site: <http://www.bb-battery.com>

USA:
B&B BATTERY(USA) INC.
6415 RANDOLPH ST.COMMERCE,
CA,90040 U.S.A.
TEL:1-323-278-1900.1-800-278-8599
FAX:1-323-278-1268
E-Mail:sales@bb-battery.com

EUROPE:
B&B BATTERY(EUROPE) B.V.
3 WIJNGAARDVELD, 9300 AALST,BELGIUM
TEL:(00)32-53781567
FAX:(00)32-53781567
E-Mail:hansdevriese@bb-battery.com

CHINA FACTORY:
B.B. BATTERY CO., LTD.
CHENG DONG TRIAL AREA,HUANG GANG,
RAOPING, GUANG DONG,CHINA,515700
TEL:86-768-7601001-2
FAX:86-768-7601469
E-Mail:maggy@bb-battery.com

HONG KONG:
NATIONAL TRADING LTD.
TEL:852-2301-3800
FAX:852-2739-1182
E-Mail:bbhk@hkstar.com

JAPAN:
B&B BATTERY(JAPAN) CO., LTD.
1375-11 NARAHARA-MACHI,HACHIOJI,
TOKYO 193-0803,JAPAN.
TEL:81-426-25-6375
FAX:81-426-25-6375
E-Mail:miyata@bb-battery.com

TAIWAN:
B.B. BATTERY(TAIWAN) CO., LTD.
TEL:886-6-502-5150
FAX:886-6-589-8087
E-Mail:maggy@bb-battery.com

