

PowerSafe[®]
Planté

Prolonged Life
High Performance Cells
YAP / YCP / YHP / U-YHP

RANGE SUMMARY



Introduction to . . . YAP / YCP / YHP / U-YHP

PowerSafe®
Planté

The EnerSys® range of PowerSafe® Planté YAP, YCP, YHP and U-YHP cells has been designed for standby power applications wherever high performance and long life are absolute requirements.

Using the traditional Planté positive plate design, refined by more than 100 years of EnerSys' battery manufacturing experience, Planté's specifications make it the ideal choice for a wide range of applications such as telecommunications, power generation and distribution, UPS, emergency lighting and security systems.

The Planté cell is unique in that it delivers 100% of its rated capacity throughout its entire life, a claim unmatched by any other lead acid battery technology. This eliminates the need to oversize the battery to allow for reduced performance towards the end of service life.

The capacity range covered by EnerSys high performance PowerSafe Planté products is 16 to 2400 ampere-hours (10h to 1.80Vpc at 20°C). YAP types cover 16 to 80Ah; YCP types 107 to 455Ah; YHP types 535 to 2139Ah and U-YHP types 600 to 2400Ah.

Construction

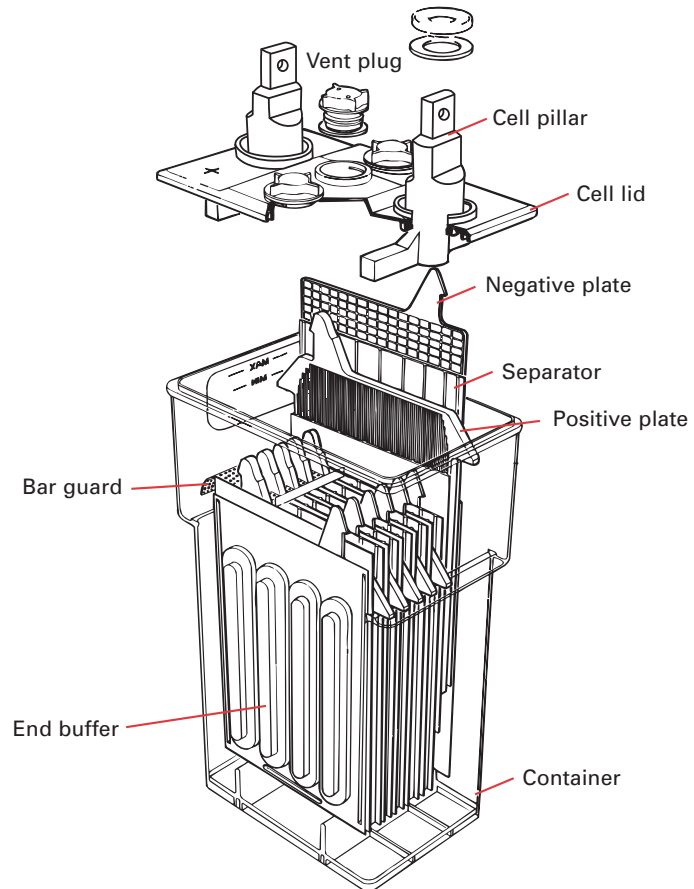

Features

- Vent plugs - designed to allow free exit of gasses, yet eliminate acid spray. Explosion minimising vent plugs are available as an option
- Cell pillars - lead alloy (YAP) with copper insert (YCP / YHP / U-YHP) designed to give minimum resistance and maximum current flow
- Cell containers - moulded from durable, transparent styrene acrylonitrile (SAN) to allow electrolyte level and cell condition to be monitored visually
- Cell lids - moulded from durable, opaque SAN sealed to container to ensure no electrolyte leakage
- Negative plates - pasted grids provide perfect balance with the positive plates to give maximum performance and service life
- Positive plates - unique, pure lead construction ensures 100% capacity throughout long service life
- Separators - made from natural ribbed microporous rubber for minimum resistance
- Bar guards - safeguard against short circuits
- End buffers - provide additional lateral support at each end of the element, ensuring a compact assembly to prevent plate movement during transit

Benefits

- High performance cells
- First choice for long life and reliability
- Excellent performance at both high and low rates of discharge
- Low internal resistance
- Retain 100% capacity throughout life
- Proven service life in excess of 20 years on float or trickle charge
- Low maintenance (periods between water addition up to 3 years) due to large electrolyte reserve

Standards

- Compliant with IEC 60896-11 and BS6290 Part 2
- Manufactured to ISO™ 9001:2008 and ISO 14001:2004 standards

General Specifications

Cell Type	Nominal Capacity (Ah)			Nominal Dimensions (mm)				Typical Weight (kg)		Electrolyte Volume S.G. = 1.207 (litres)	Pillars per Pole ⁽⁴⁾	Internal Resistance ($\mu\Omega$)
	3h to 1.80Vpc @ 20°C	10h to 1.85Vpc @ 15°C	10h to 1.80Vpc @ 20°C ⁽¹⁾	Length ⁽²⁾	Width ⁽³⁾	Height over Lid	Overall Height of Cell	Filled	Dry			
YAP 5	12.5	15	16	76	133	220	260	3.0	2.0	1.0	1	5195
YAP 9	25	30	32	114	133	220	260	5.5	4.0	1.6	1	2597
YAP 13	37.5	45	48	190	133	220	260	9.0	5.5	2.8	1	1732
YAP 17	50	60	64	190	133	220	260	10.5	7.5	2.7	1	1299
YAP 21	62.5	75	80	228	133	220	260	11.0	9.0	3.2	1	1039
YCP 9	83	100	107	134	203	354	423	17.5	12.0	4.6	1	923
YCP 11	103.5	125	134	172	203	354	423	21.0	14.0	5.8	1	754
YCP 13	124	150	160	172	203	354	423	23.5	17.0	5.4	1	640
YCP 17	165.5	200	214	210	203	354	423	28.0	21.5	5.4	1	500
YCP 21	207	250	267	248	203	354	423	36.0	27.0	10.8	1	417
YCP 25	248	300	321	286	203	354	423	42.5	31.5	9.2	1	364
YCP 27	269	325	348	362	203	354	423	46.5	34.5	9.9	1	344
YCP 29	290	350	374	362	203	354	423	48.0	36.0	14.5	1	327
YCP 33	331	400	428	362	203	354	423	53.5	41.5	10.0	1	300
YCP 35	352	425	455	362	203	354	423	58.0	43.0	12.5	1	290
YHP 11	422	500	535	230	368	596	682	88.0	57.0	25.7	1	351
YHP 13	506	600	642	230	368	596	682	98.0	67.0	25.7	1	293
YHP 15	591	700	749	306	368	596	682	109.0	79.5	24.5	2	251
YHP 17	675	800	856	306	368	596	682	137.0	93.5	36.0	2	220
YHP 19	760	900	962	306	368	596	682	148.0	103.5	37.0	2	195
YHP 21	844	1000	1069	357	368	596	682	162.5	113.5	41.6	2	176
YHP 23	928	1100	1176	357	368	596	682	171.5	123.9	39.5	2	160
YHP 25	1013	1200	1283	433	368	596	682	184.5	135.5	41.0	2	146
YHP 27	1097	1300	1390	433	368	596	682	209.0	146.5	51.8	2	135
YHP 29	1182	1400	1497	433	368	596	682	218.0	157.0	50.6	2	126
YHP 31	1266	1500	1604	509	368	596	682	227.0	167.0	49.8	3	117
YHP 33	1351	1600	1711	509	368	596	682	256.0	183.0	60.5	3	110
YHP 35	1435	1700	1818	509	368	596	682	265.0	193.0	59.8	3	104
YHP 37	1519	1800	1925	585	368	596	682	274.0	204.0	58.1	3	98
YHP 39	1604	1900	2032	585	368	596	682	301.0	217.0	69.7	3	93
YHP 41	1689	2000	2139	585	368	596	682	310.0	227.0	68.8	3	88
U-YHP 600	435	-	600	230	368	596	682	88.0	57.0	25.7	1	351
U-YHP 720	522	-	720	230	368	596	682	98.0	67.0	25.7	1	293
U-YHP 840	609	-	840	306	368	596	682	109.0	79.5	24.5	2	251
U-YHP 960	696	-	960	306	368	596	682	137.0	93.5	36.0	2	220
U-YHP 1080	783	-	1080	306	368	596	682	148.0	103.5	37.0	2	195
U-YHP 1200	870	-	1200	357	368	596	682	162.5	113.5	41.6	2	176
U-YHP 1320	957	-	1320	357	368	596	682	171.5	123.9	39.5	2	160
U-YHP 1440	1044	-	1440	433	368	596	682	184.5	135.5	41.0	2	146
U-YHP 1560	1131	-	1560	433	368	596	682	209.0	146.5	51.8	2	135
U-YHP 1680	1218	-	1680	433	368	596	682	218.0	157.0	50.6	2	126
U-YHP 1800	1305	-	1800	509	368	596	682	227.0	167.0	49.8	3	117
U-YHP 1920	1392	-	1920	509	368	596	682	256.0	183.0	60.5	3	110
U-YHP 2040	1479	-	2040	509	368	596	682	265.0	193.0	59.8	3	104
U-YHP 2160	1566	-	2160	585	368	596	682	274.0	204.0	58.1	3	98
U-YHP 2280	1653	-	2280	585	368	596	682	301.0	217.0	69.7	3	93
U-YHP 2400	1740	-	2400	585	368	596	682	310.0	227.0	68.8	3	88

Notes:

- (1) Capacities as per IEC 60896-11
- (2) The length of a box or cell is measured at right angles to the plates
- (3) The width of a cell is measured parallel to the plates
- (4) YAP cells: M6 fasteners - YCP / YHP / U-YHP cells: M8 fasteners

Battery Accommodation

By following the guidelines hereafter, the user can readily calculate the space required by the various standard range of steel stand options to make best use of the accommodation available.

Stand Dimensions for YAP & YCP Ranges

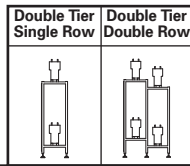

		Double Tier Single Row	Double Tier Double Row
YAP 5 (F)	Cell centres	83	83
	Width of stand	320	615
	Height over cells	1200	1300
	Overall height required (min.)	1360	1460
	Length of stand	12 cells	525
24 cells		1020	525
55 cells		-	1190
YAP 9 (F)	Cell centres	121	121
	Width of stand	320	615
	Height over cells	1200	1300
	Overall height required (min.)	1360	1460
	Length of stand	12 cells	750
24 cells		1480	750
55 cells		-	1720
YAP 13 YAP 17 YAP 21 (E)	Cell centres	140	140
	Width of stand	320	615
	Height over cells	1200	1300
	Overall height required (min.)	1360	1460
	Length of stand	12 cells	865
24 cells		1710	865
55 cells		-	1990
YAP 9 (F)	Cell centres	140	140
	Width of stand	320	615
	Height over cells	1370	1470
	Overall height required (min.)	1620	1720
	Length of stand	12 cells	865
24 cells		1710	865
55 cells		-	1990
YAP 11 YAP 13 (F)	Cell centres	178	178
	Width of stand	320	615
	Height over cells	1370	1470
	Overall height required (min.)	1620	1720
	Length of stand	12 cells	1095
24 cells		2165	1095
55 cells		-	2510
YCP 17 YCP 21 (E)	Cell centres	209	209
	Width of stand	320	615
	Height over cells	1370	1470
	Overall height required (min.)	1620	1720
	Length of stand	12 cells	1270
24 cells		2540	1270
55 cells		-	2960
YCP 25 YCP 27 YCP 29 YCP 33 YCP 35 (E)	Cell centres	209	209
	Width of stand	430	835
	Height over cells	1370	1470
	Overall height required (min.)	1620	1720
	Length of stand	12 cells	1270
24 cells		2540	1270
55 cells		-	2960

Calculating other lengths of stands:

- For Double tier single row length = $C \times N/2 + 25\text{mm}$
 - For Double tier double row length = $C \times N/4 + 25\text{mm}$,
 where C = cell centre and N = number of cells
 If N/2 or N/4 contains a fraction, increase to next whole number.

Stand Dimensions for YHP & U-YHP Ranges

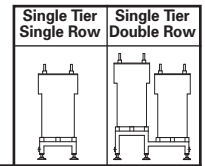

		Single Tier Single Row	Single Tier Double Row
YHP 11 YHP 13 U-YHP 600 U-YHP 720 (F)	Cell centres	255	255
	Width of stand	340	760
	Height over cells	880	980
	Overall height required (min.)	1130	1230
	Length of stand	6 cells	1550
12 cells		3080	1550
YHP 15 YHP 17 YHP 19 U-YHP 840 U-YHP 960 U-YHP 1080 (F)	Cell centres	330	330
	Width of stand	340	760
	Height over cells	880	980
	Overall height required (min.)	1130	1230
	Length of stand	6 cells	2000
12 cells		-	2000
YHP 21 YHP 23 U-YHP 1200 U-YHP 1320 (E)	Cell centres	394	394
	Width of stand	360	760
	Height over cells	880	980
	Overall height required (min.)	1130	1230
	Length of stand	6 cells	2375
12 cells		-	2375
YHP 25 YHP 27 YHP 29 U-YHP 1440 U-YHP 1560 U-YHP 1680 (E)	Cell centres	394	394
	Width of stand	435	920
	Height over cells	880	980
	Overall height required (min.)	1130	1230
	Length of stand	6 cells	2375
12 cells		-	2375
YHP 31 YHP 33 YHP 35 U-YHP 1800 U-YHP 1920 U-YHP 2040 (E)	Cell centres	394	394
	Width of stand	510	1070
	Height over cells	880	980
	Overall height required (min.)	1130	1230
	Length of stand	6 cells	2375
12 cells		-	2375
YHP 37 YHP 39 YHP 41 U-YHP 2160 U-YHP 2280 U-YHP 2400 (E)	Cell centres	394	394
	Width of stand	585	1220
	Height over cells	880	980
	Overall height required (min.)	1130	1230
	Length of stand	6 cells	2375
12 cells		-	2375

Notes:

The suffixes 'E' and 'F' refer to the layout of the cells on the stand:
 • 'E' signifies that the cells are arranged with the plates edge to edge
 • 'F' signifies that they are arranged with the plates face to face

Layout for YAP & YCP Ranges

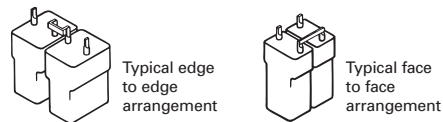

Layout for YHP & U-YHP Ranges

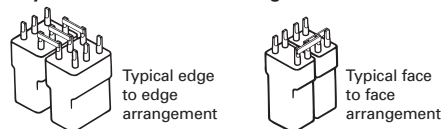

www.enersys-emea.com

EnerSys
 P.O. Box 14145
 Reading, PA 19612-4145
 USA
 Tel: +1-610-208-1991
 +1-800-538-3627
 Fax: +1-610-372-8613

EnerSys Europe
 Löwenstrasse 32
 8001 Zurich, Switzerland

EnerSys Asia
 152 Beach Road
 Gateway East Building
 Level 11
 189721 Singapore
 Tel. +65 6508 1780

EnerSys Ltd.
 Oak Court
 Clifton Business Park
 Wynne Avenue
 Swinton, Manchester
 M27 8FF, UK
 Tel: +44 (0)161 794 4611
 Fax: +44 (0)161 727 3809

Contact:

© 2010 EnerSys. All rights reserved.
 Trademarks and logos are the property of EnerSys and its affiliates, except ISO™, which is not the property of EnerSys.