

---

# MOSA

---

## *GI 2000 SX*

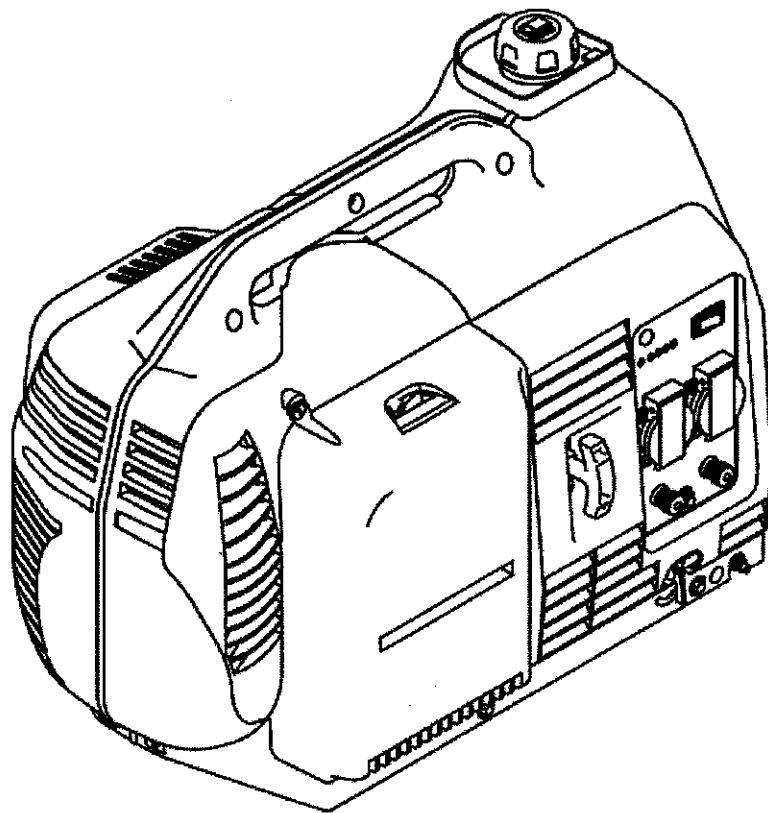

### OWNER' S MANUAL

# CONTENTS

---

1 . SAFETY INSTRUCTIONS	2
2 . SAFETY LABEL LOCATION	4
CE mark and noise label locations	5
3 . COMPONENT IDENTIFICATION	6
4 . PRE-OPERATION CHECK	8
5 . OPERATION	11
START ENGINE	13
USE GENERATOR	14
STOP ENGINE	15
6 . MAINTENANCE	16
7 . TROUBLESHOOTING	19
8 . SPECIFICATIONS	20
9 . WIRING DIAGRAM	21
10. TRANSPORTING/STORAGE	22

# 1. SAFETY INSTRUCTIONS

---

## WARNING



Operate the generator on a leveled surface.  
If the generator is tilted, fuel spillage may result.  
Place the generator at least 1m away from buildings or other equipment during operation.  
Keep children and pets away from the generator when it is in operation.



Do not open the generator or work on the generator without first consulting the owner's manual thoroughly.  
If this manual is not 100% clear to you, please consult an authorised dealer.



Read and understand the Owner's Manual before operating the generator. Failure to do so could result in personal injury or equipment damage.



Exhaust gas contains poisonous carbon monoxide.  
Never run the generator in an enclosed area.  
Be sure to provide adequate ventilation.



Gasoline is extremely flammable and explosive under certain conditions.  
Refuel in a well-ventilated area with the engine stopped.  
Keep away from open fire, cigarettes, smoke and sparks of any kind when refueling the generator or when near gasoline storage.  
Always refuel in a well-ventilated location.  
Wipe up spilled gasoline at once.



Do not operate the generator in rain or snow and do not let it get wet.



The generator is a potential source of electrical shocks when misused. Do not operate with wet hands.



Use automotive gasoline with a pump octane number of 86 or higher, or a research octane number of 91 or higher.  
Unleaded is preferred to minimize combustion chamber deposits.

# SAFETY INSTRUCTIONS

---



Connections for standby power to a building's electrical system must be made by a qualified electrician and must comply with all applicable laws and electrical codes. Improper connections can allow electrical current from the generator to back feed into the utility lines. Such back feed may electrocute utility company workers or others who contact the lines during a power outage, and when utility power is restored, the generator may explode, burn, or cause fires in the building's electrical system.



The muffler becomes very hot during operation and remains hot for a while after stopping the engine. Be careful not to touch the muffler while it is hot. Let the engine cool down before storing the generator indoors.

The engine exhaust system will be heated during operation and remain hot immediately after stopping the engine. To prevent scalding, pay attention to the warning marks attached to the generator.

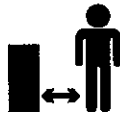

Hot area. Keep appropriate distance.

## 2. SAFETY LABEL LOCATION

These labels warn you of potential hazards that can cause serious injury.

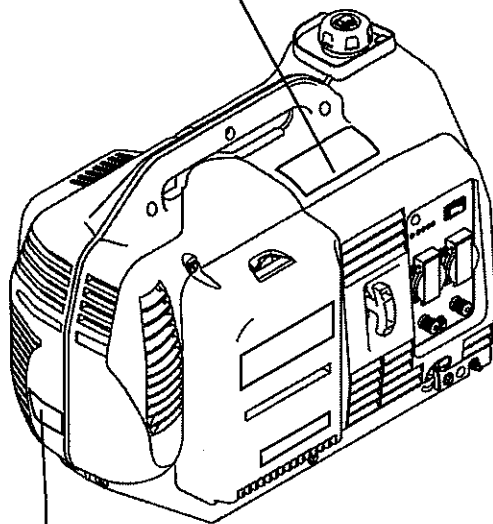
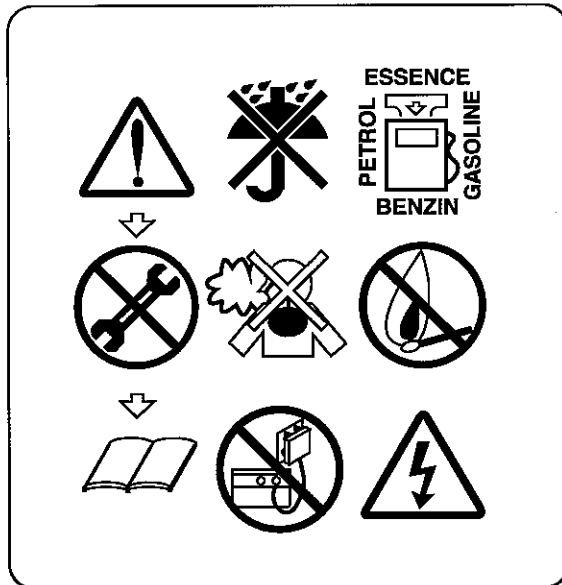

HOT CAUTION

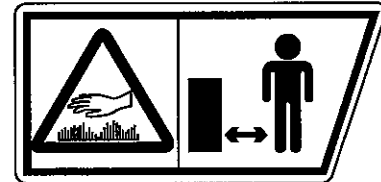

HOT CAUTION

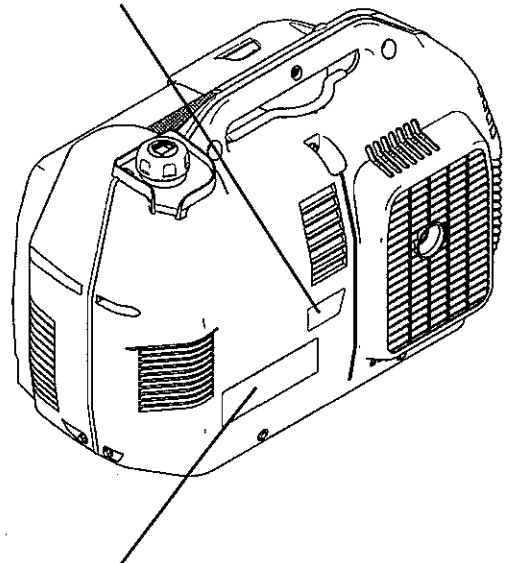

FUEL CAUTION

 STOP THE ENGINE BEFORE REFUELING.  
 Ⓟ ARRÊTEZ LE MOTEUR AVANT DE REFAIRE LE PLEIN.  
 Ⓛ VOR AUFTANKEN NUR TOR ABSTELLEN.  
 Ⓛ ARRESTARE IL MOTORE PRIMA DI FARE RIFORMIMENTO.  
 Ⓛ STOP DE MOTOR ALVORENS BIJ TE TANKEN.  
 Ⓟ PARE EL MOTOR ANTES DE REPOSTAR.  
 Ⓟ DESLIGUE O MOTOR ANTES DE ABASTECER.  
 Ⓟ ΣΤΑΜΑΤΑΤΕ ΤΗ ΜΗΧΑΝΗ ΠΡΙΝ ΤΟΝ ΑΝΕΦΟΔΙΑΣΜΟ ΜΕ ΚΑΥΣΙΜΑ.  
 Ⓟ STÅNG AV MOTORN FÖRE BRÄNSLEPÅFYLLNING.  
 Ⓟ STOP MOTOREN FÖR BRÄNSTOFFPÅFYLLNING.  
 Ⓟ SLÅ AV MOTOREN FÖR PÅFYLLNING.  
 Ⓟ SAMMUTA MOOTTORI ENNEN TANKKAUSTA.

# CE mark and noise label location

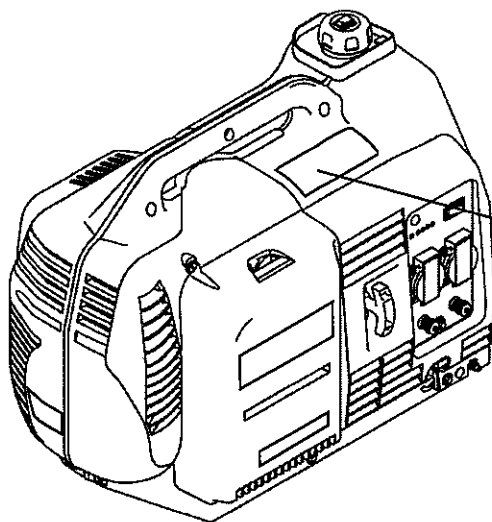

CE MARK

<b>CE</b>	<b>GI 2000 SX</b>	
	INVERTER GENERATOR with HONDA GX100 ENGINE	
		MADE IN JAPAN
<small>MOSA Divisione della BCS S.p.A. Viale Europa, 69 20090 CUSAGO (MI) Italy</small>		
<b>AC</b>	kVA	1.7
	VOLTAGE	230V
	FREQUENCY	50Hz
	RATED CURRENT	6.4A
	RATED POWER	1.5kW
	POWER FACTOR	1.0
	RPM	4500
<b>DC</b>	VOLTAGE	12V
	CURRENT	8.3A
ISO 8528-8		WEIGHT 22kg
QUALITY CLASS G1		YEAR 2005

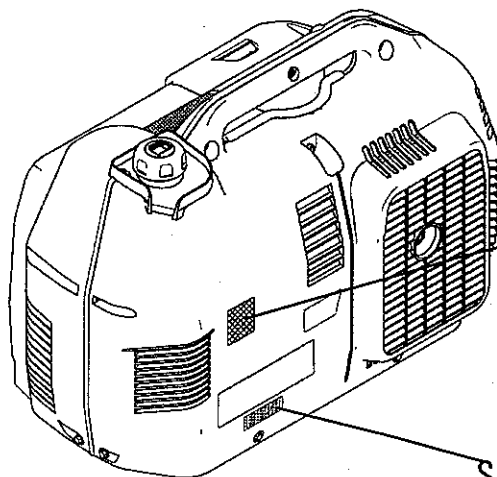

NOISE LABEL

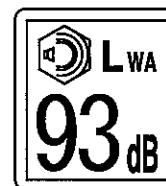

SERIAL NUMBER

# 3. COMPONENT IDENTIFICATION

---

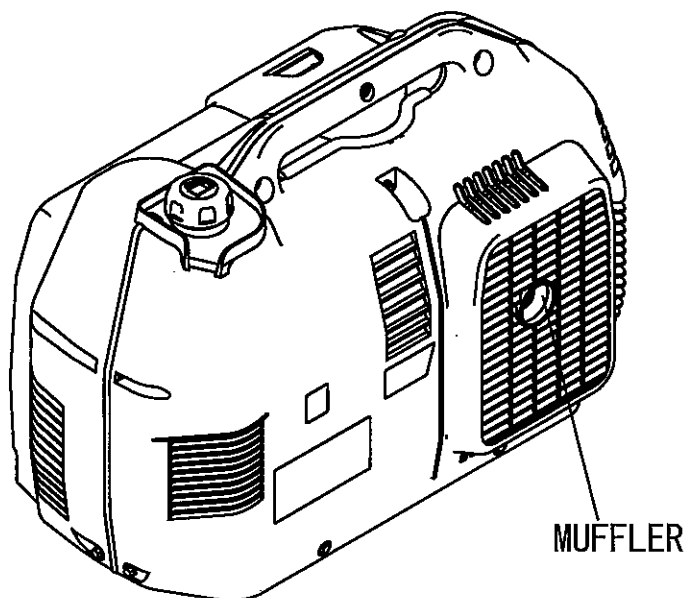
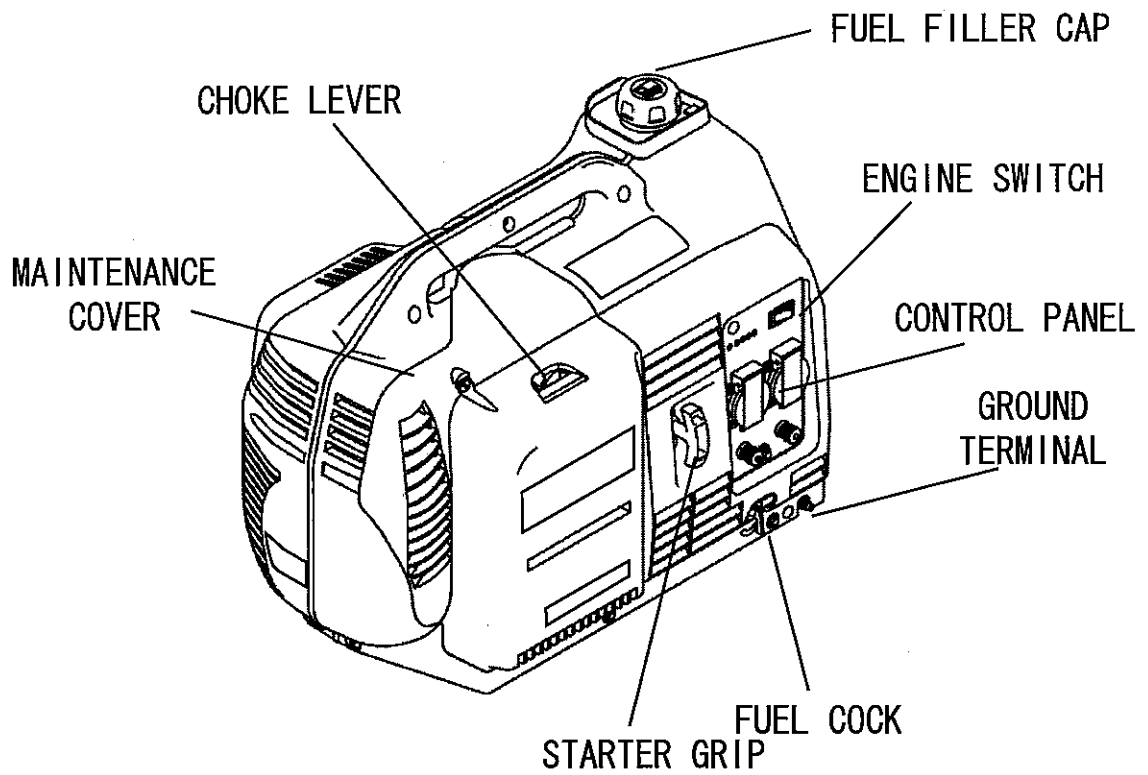

# COMPONENT IDENTIFICATION

## CONTROL PANEL

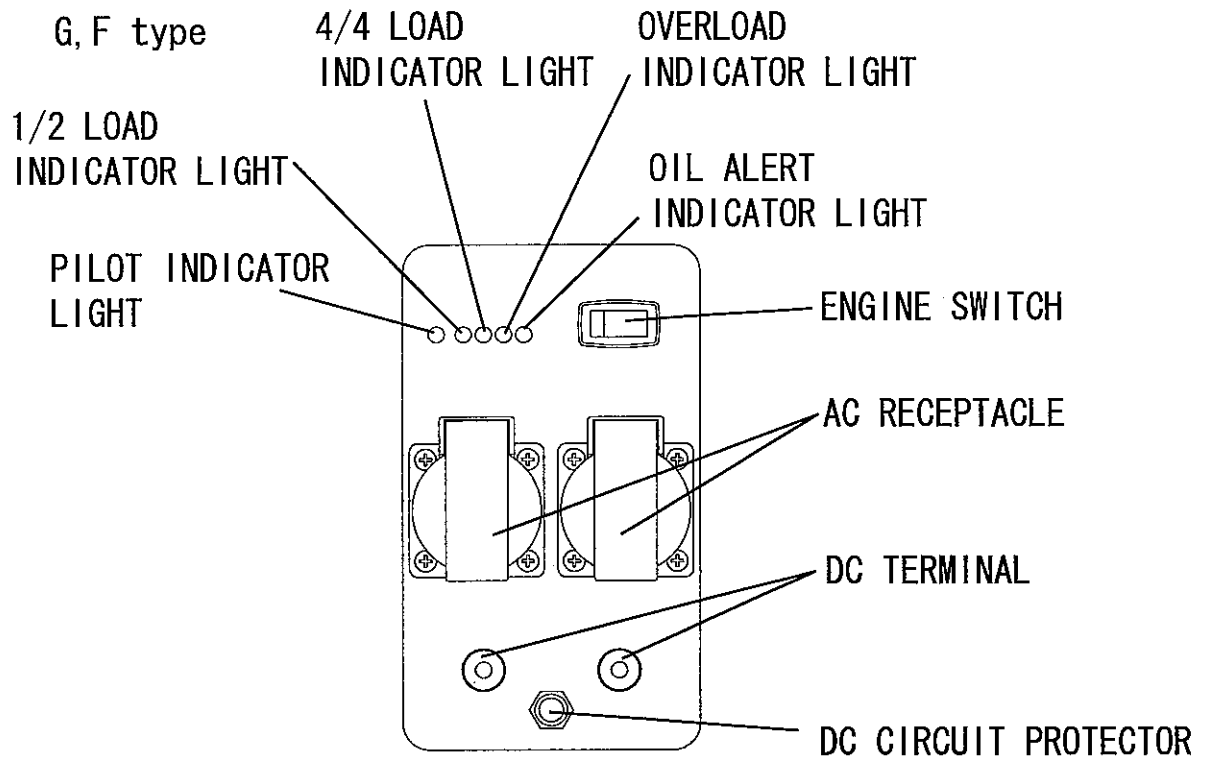

## B type

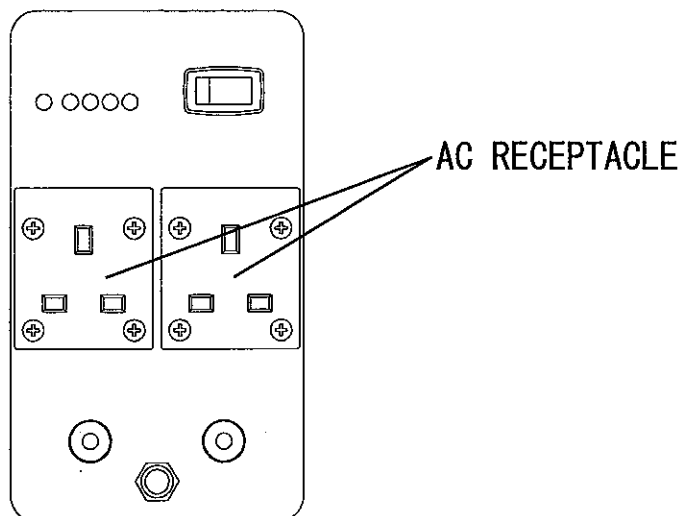



## 4. PRE-OPERATION CHECK

### CAUTION

Be sure to check the generator on a leveled surface with the engine stopped.

### 1. Check the engine oil level.

Open the maintenance cover with screwdriver.  
Check the oil level by inserting the dipstick in the filler hole without screwing it in.  
If the oil level is below the end of the dipstick, refill the recommended oil up to the top of the oil filler neck.

Select the appropriate viscosity for the average temperature in your area.

SAE Viscosity Grade

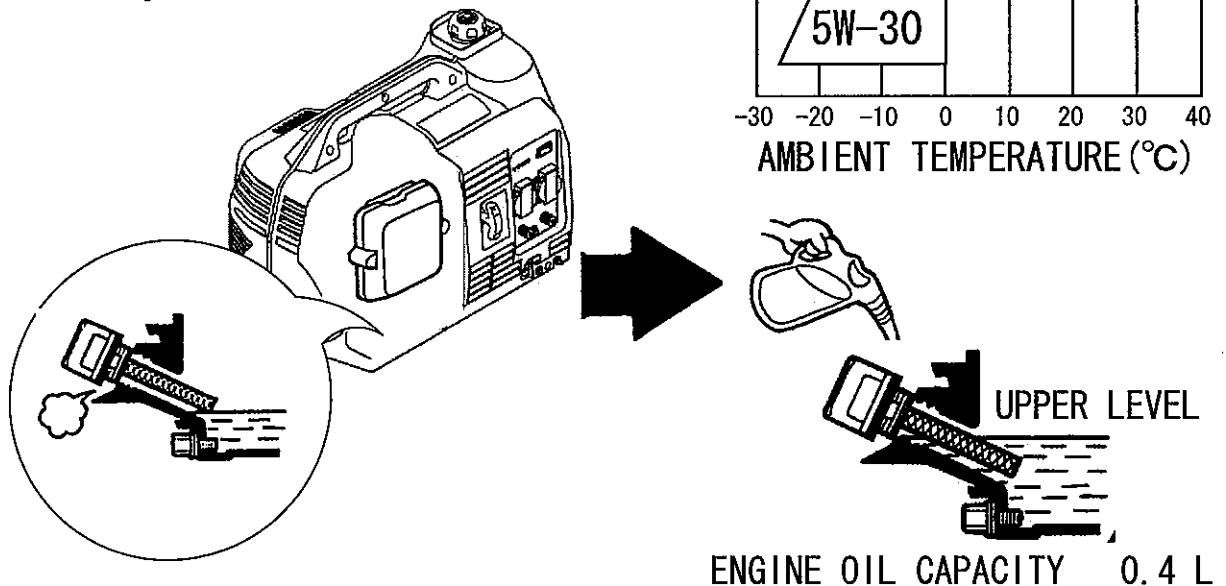
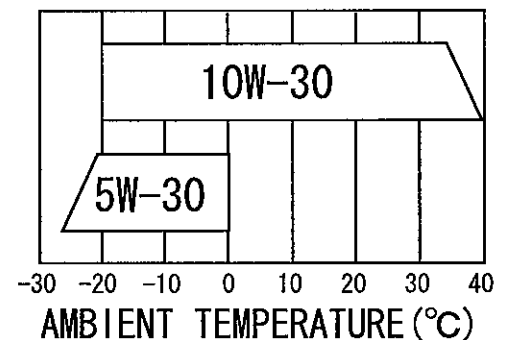

### CAUTION

Running the engine with insufficient oil can cause serious engine damage.

### NOTE

The oil alert system will automatically stop the engine before the oil level falls below the safety limit. However, to avoid the inconvenience of an unexpected shutdown, it is still advisable to visually inspect the oil level regularly.

# PRE-OPERATION CHECK

---

## 2. Check the fuel level.

Use automotive gasoline.

If the fuel level is low, refuel the fuel tank until the level as specified in drawing.

Never use an oil/gasoline mixture or dirty gasoline.

Avoid dirt, dust or water from getting in the fuel tank.

After refueling, tighten the fuel filler cap securely.

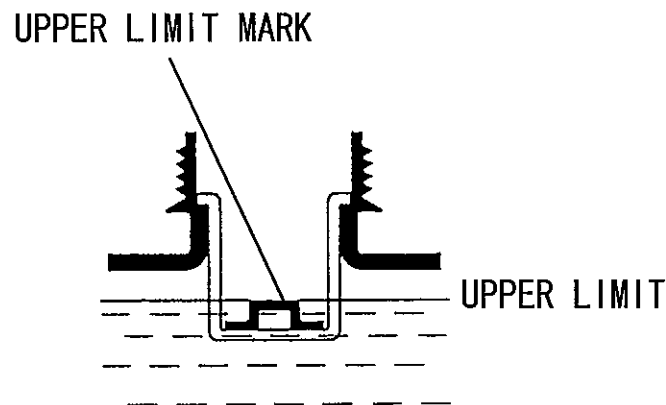

## WARNING

Gasoline is extremely flammable and explosive under certain conditions.

Refuel in a well-ventilated area with the engine stopped.

Do not smoke or allow flame or sparks in the area where the engine is refueled or where gasoline is stored.

Do not overfill the fuel tank (there should be no fuel above the upper limit mark). After refueling, make sure the tank cap is closed properly and securely.

Be careful not to spill fuel when refueling. Spilled fuel or vapor may ignite. If any fuel is spilled, make sure the area is dry before starting the engine.

Avoid repeated or prolonged contact with skin or breathing of vapor. KEEP OUT OF REACH OF CHILDREN.

# PRE-OPERATION CHECK

---

## Gasolines containing alcohol

If you decide to use a gasoline containing alcohol (gasohol), be sure it's octane rating is at least as high as that recommended by MOSA. There are two types of "gasohol": one containing ethanol, and the other containing methanol. Do not use gasohol that contains more than 10% ethanol. Do not use gasoline containing methanol (methyl or wood alcohol) that does not also contain cosolvents and corrosion inhibitors for methanol. Never use gasoline containing more than 5% methanol, even if it has cosolvents and corrosion inhibitors.

## NOTE

Fuel system damage or engine performance problems resulting from the use of fuels that contain alcohol is not covered under the warranty. MOSA cannot endorse the use of fuels containing methanol since evidence of their suitability is as yet incomplete.

Before buying fuel from an unfamiliar station, try to find out if the fuel contains alcohol. If it does, confirm the type and percentage of alcohol used. If you notice any undesirable operating symptoms while using a gasoline that contains alcohol, or one that you think contains alcohol, switch to a gasoline that you know does not contain alcohol.

## 3. Check the air cleaner.

Check the air cleaner element to be sure it is clean and in good condition.

Clean or replace the element if necessary. (see page 17)

## CAUTION

Never run the engine without the air cleaner. Rapid engine wear will result from contaminants, such as dust and dirt, being drawn through the carburetor, into the engine.

# 5. OPERATION

---

## WARNING

Do not remove the maintenance cover when the engine is running. To prevent electrical shock from faulty appliance, the generator should be grounded. Connect a length of heavy wire between the generator's ground terminal and external ground source.

## CAUTION

Do not exceed the rated power. The total wattage of all appliances connected must be considered. (Most appliance motors require more than their rated wattage for start-up)

Do not exceed the current limit specified for any one receptacle.

Do not connect the generator to a household circuit.

This could cause damage to the generator or to electrical appliances in the house.

Do not connect the generators in parallel.

When an extension cable is required, be sure to use a tough rubber sheathed flexible cable (IEC245 or equivalent).

Limit length of extension cables; 60m for cables of 1.5mm<sup>2</sup> and 100m for cables of 2.5mm<sup>2</sup>. Long extension cables will lower usable power due to resistance in the extension cable.

Keep the generator away from other electric cables or wires such as commercial power supply lines.

## HIGH ALTITUDE OPERATION/HOT ENVIRONMENT OPERATION

Performance will decrease, and fuel consumption will increase.

# OPERATION

---

## OIL ALERT SYSTEM

The oil alert system is designed to prevent engine damage caused by an insufficient amount of oil in the crankcase. Before the oil level in the crankcase falls below the safety limit, the oil alert system will automatically shut down the engine (the engine switch will remain in the ON position). If the oil alert system shuts down the engine, the oil alert indicator lamp (red) lights up when you operate the starter, and the engine will not run. If it occurs, add engine oil.

## CAUTION

Never run the engine without the air cleaner. Rapid engine wear will result from contaminants, such as dust and dirt, being drawn through the carburetor, into the engine.

## LOAD INDICATOR LIGHTS

Pilot indicator lamp lights up as soon as engine is started.

1/2 load and 4/4 load indicator lamps light up when the respective charge is reached.

In case of overcharge, the overload indicator lamp lights up immediately, and the output voltage will be switched off within 20 seconds.

# OPERATION

---

## START ENGINE

1. Engine switch to the "ON" position and move the choke lever to "CLOSE". Turn the fuel cock to the "ON" position.

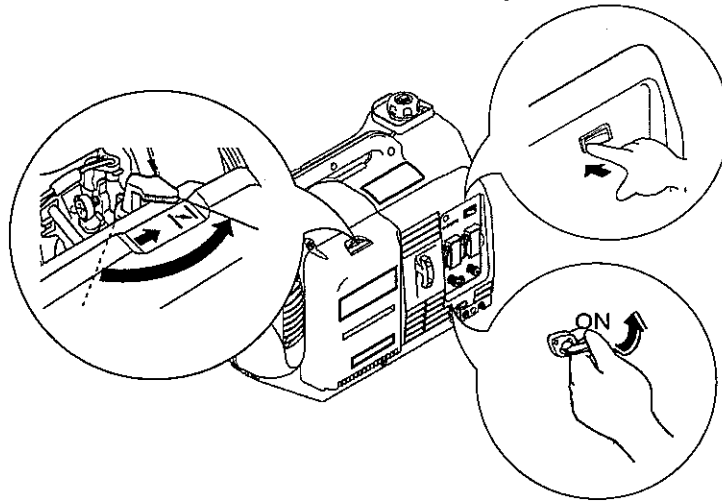

2. Pull the starter grip lightly until resistance is felt, then pull briskly.

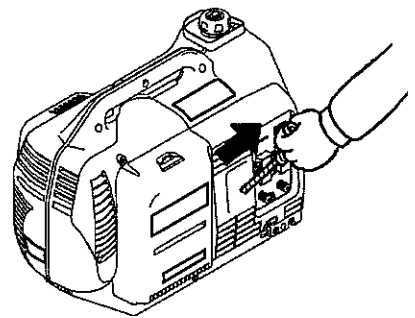

3. Move the choke lever to "OPEN" as the engine warms up.

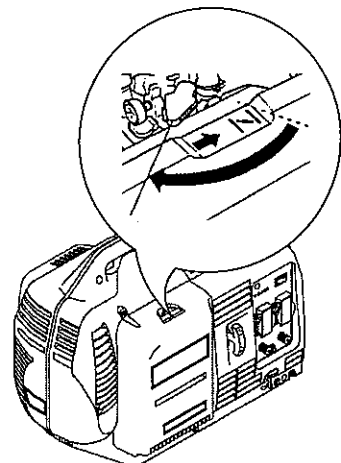

# OPERATION

## USE GENERATOR

### AC APPLICATION

1. Make sure the pilot indicator lamp lights up.
2. Plug in the appliance.
3. Overload

In case of overload, the overload indicator lamp will light up immediately. After 20 seconds, the output voltage will be switched off automatically.

Stop the engine to reset. Wait 30 seconds, then start the engine again.

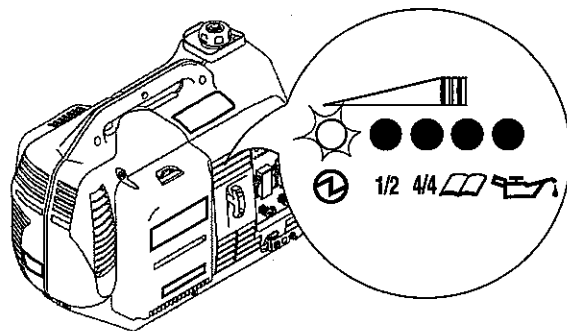

### DC APPLICATION

NOTE : The DC terminals may be used for charging 12 volt automotive-type batteries only.

1. Make sure that the generator is not running.
2. Connect the charging cables to the battery terminals and then to the DC terminals of the generator.  
Connect the "+" terminal of the battery to the DC terminal "+" and the "-" terminal of the battery to the DC terminal "-".
3. Set the engine switch to "ON" and start the engine.

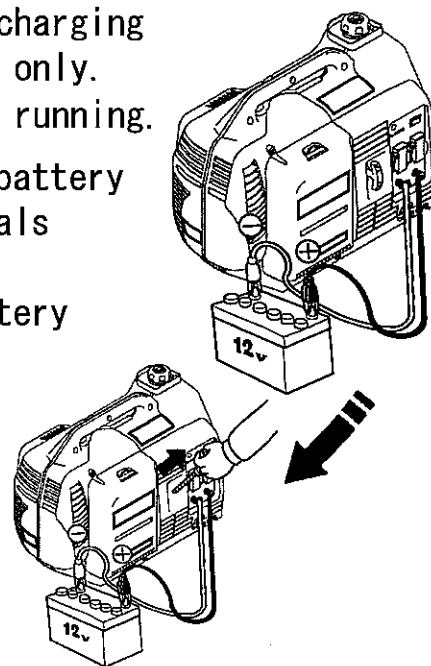

### WARNING

The battery gives off explosive gases; keep sparks, flames and cigarettes away. Provide adequate ventilation when charging. The battery contains sulfuric acid (electrolyte). Contact with skin or eyes may cause severe burns. Wear protective clothing and a face shield.

-If electrolyte gets on your skin, flush with water.

-If electrolyte gets in your eyes, flush with water for at least 15 minutes and call a physician.

Electrolyte is poisonous.

-If swallowed, drink large quantities of water or milk and follow with vegetable oil or milk of magnesia and call a physician.

KEEP OUT OF REACH OF CHILDREN.

# OPERATION

---

## CAUTION

Do not attempt to start an automobile engine with the generator still connected to the battery. The generator may be damaged. Connect the positive battery terminal to the positive DC terminal. Do not reverse the charging cables, or serious damage to the generator and/or battery may occur.

## COMBINED AC, DC APPLICATION

It is allowed to combine AC DC applications. Performance will decrease, and fuel consumption will increase.

AC ONLY  
1.5 kW

COMBINED  
AC 1.4 kW + DC 8.3A

---

## STOP ENGINE

1. Disconnect the electrical appliance.
2. Turn the engine switch to the "OFF" position.
3. Turn the fuel cock to the "OFF" position.

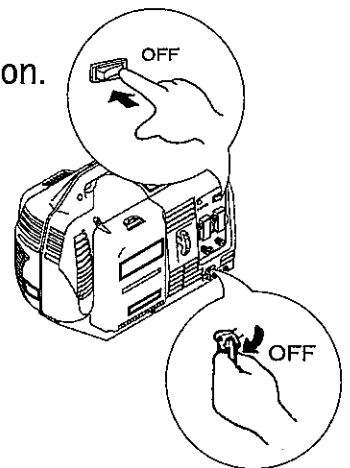

To stop the engine in an emergency, turn the engine switch to the OFF position.



## 6. MAINTENANCE

The purpose of the maintenance and adjustment schedule is to keep the generator in the best operating condition.

### WARNING

Shut off the engine before performing any maintenance.  
If the engine has to run, make sure the area is well ventilated.  
The exhaust contains poisonous carbon monoxide gas.

### MAINTENANCE SCHEDULE

ITEM	REGULAR SERVICE PERIOD	Each use	First month	Every 3 months	Every 6 months	Every 3 years
			or 20 hrs.	or 50 hrs.	or 100 hrs.	or 300 hrs.
Performed at every indicated month or operating hour interval, whichever comes first.						
Engine oil	Check level	○				
	Change		○		○	
Air cleaner	Check	○				
	Clean			○*		
Spark plug	Check-adjust				○	
	Replace					○
Valve clearance		Contact your dealer once a year.				
Fuel filter		Contact your dealer once a year.				

NOTE : \* Service more frequently when used in dusty areas.

# MAINTENANCE

## 1. AIR CLEANER SERVICE

1. Open the maintenance cover with screwdriver or coin.
2. Open the air cleaner cover with screwdriver or coin.
3. Check air cleaner foam element and wash if necessary in warm soapy water.
4. Check air cleaner paper element by tapping it lightly to remove the dust.

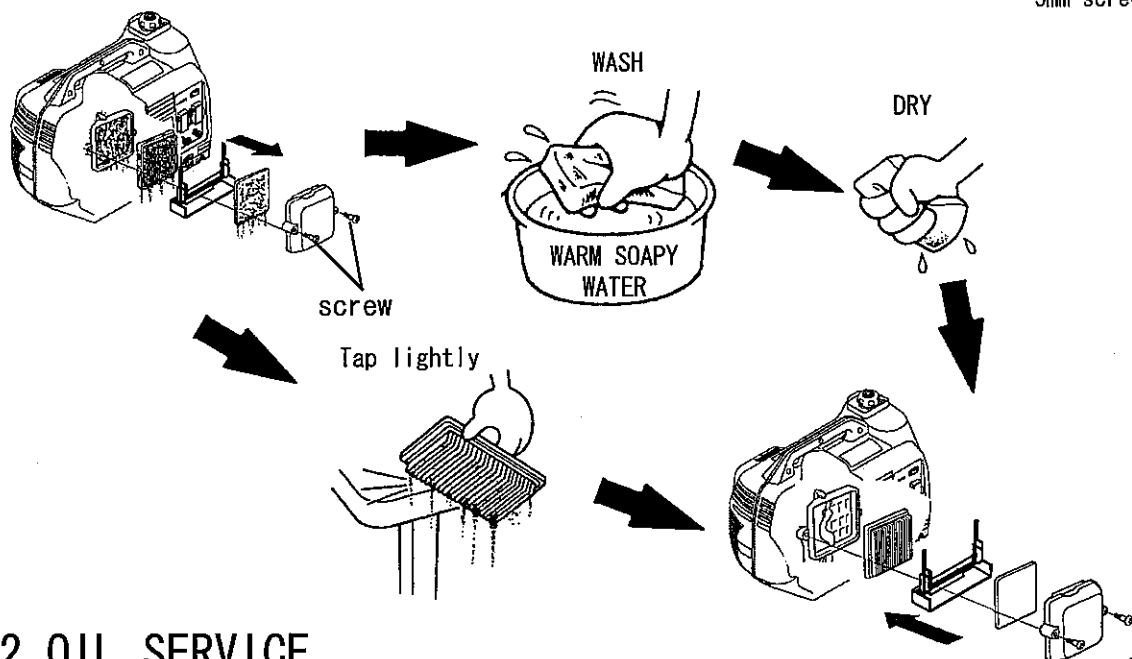
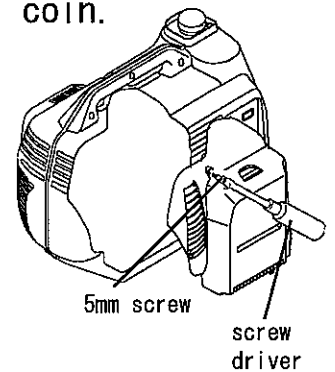

## 2. OIL SERVICE

1. Check the engine oil level.  
( see page 8 )
2. Change the engine oil.
  1. Open the maintenance cover.
  2. Drain the oil while the engine is still warm.
  3. Refill with the recommended oil and check the oil level (see page 8 )
  4. Reinstall the maintenance cover.

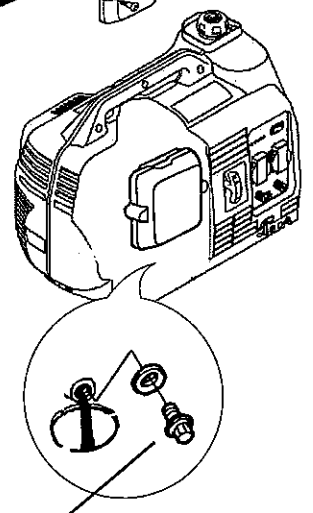

# MAINTENANCE

## 3. SPARK PLUG SERVICE

RECOMMENDED SPARK PLUG

NGK : CR5HSB

DENSO : U16FSR-UB

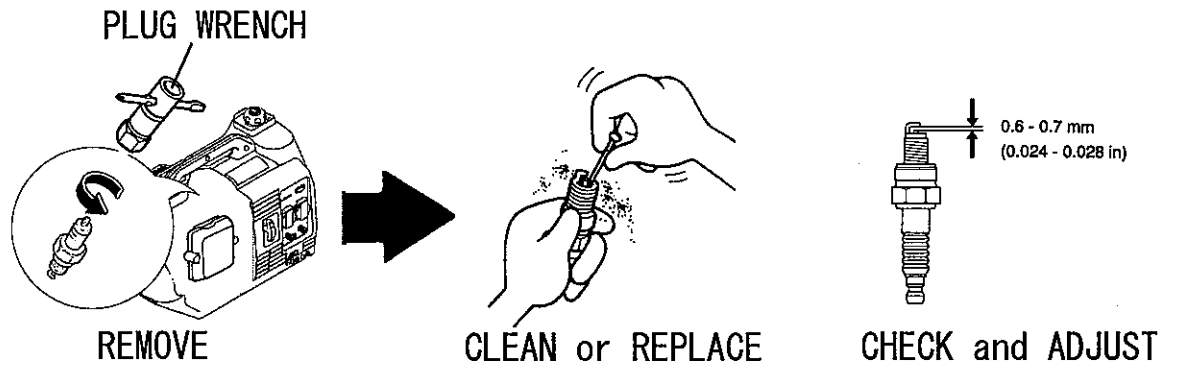

# 7. TROUBLESHOOTING

## ENGINE DOES NOT START

CHECK FUEL

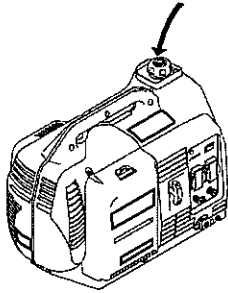

CHECK OIL

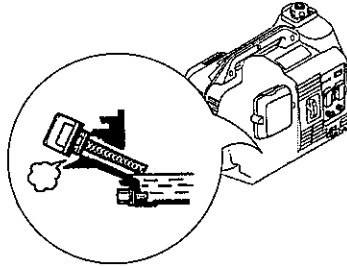

CHECK SPARK PLUG

1. Remove the spark plug and install the spark plug in the plug cap.

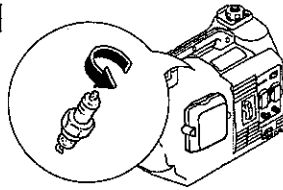

2. Set the plug side electrode on the cylinder head to ground.
3. Pull the recoil starter, sparks should jump across the gap.

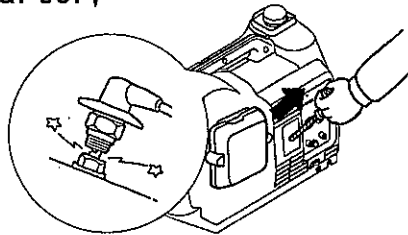

## NO ELECTRICITY

CHECK INDICATOR

1. If the OVERLOAD lamp lights up.

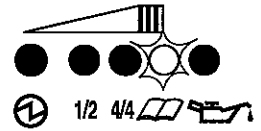

2. Stop the engine.

**WAIT 30 seconds**  
and check appliance

3. Restart the engine.

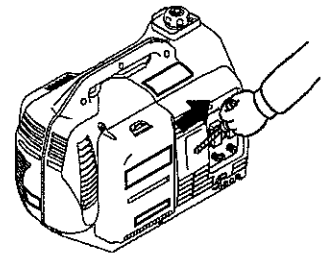

IF ENGINE STILL DOES NOT START or  
IF THERE IS STILL NO OUTPUT VOLTAGE,

PLEASE CONTACT YOUR DEALER.



# 8.SPECIFICATIONS

## Dimensions and Weight

Model	GI 2000 SX
Length x Width x Height	560 x 340 x 415 mm
Dry weight	22 kg

## Engine

Maker	HONDA
Model	GX100
Engine type	Air cooled 4-stroke OHC Gasoline
Displacement	98 cc
Oil capacity	400 cc
Fuel tank capacity	7.7 L
Spark plug	NGK:CR5HSB DENSO:U16FSR-UB
RPM	4500

## Generator

Model		INVERTER 1.7KVA
Type		G B F
AC Output	Rated Voltage(V)	230
	Rated Frequency(Hz)	50
	Rated Ampere(A)	6.4
	Rated Output(kW)	1.5
	MAX Output(kW)	1.7
	Rated Power Factor	1.0
	Telephone Harmonic Factor	20%(square wave)
DC Output		Only for charging 12V automotive batteries. Maximum charging output = 8.3 A
EU Guaranteed Sound Power Level (LWA)		93dB

NOTE : Specifications are subject to change without notice.

# 9. WIRING DIAGRAM

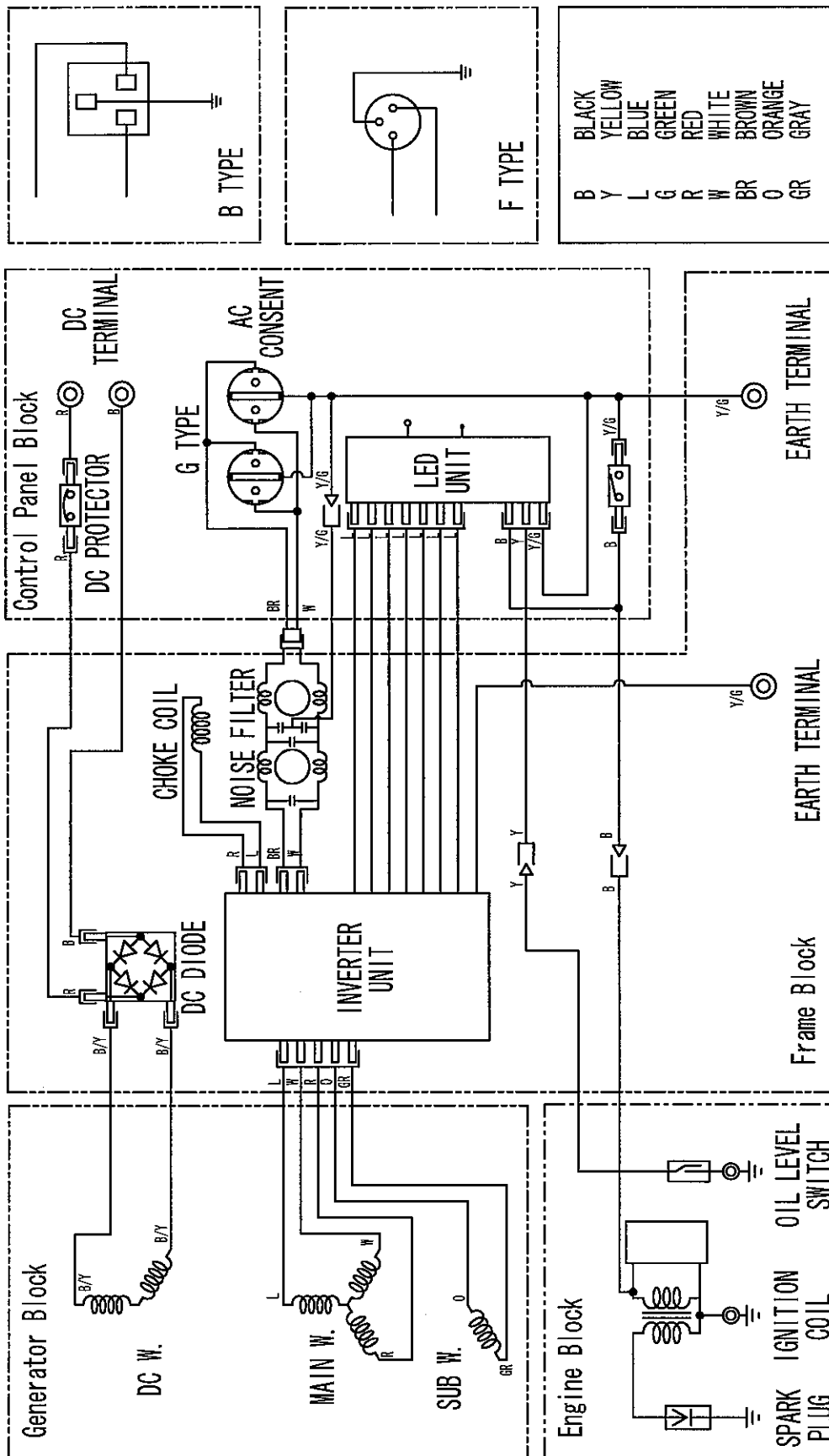

# 10. TRANSPORTING/STORAGE

---

To prevent fuel spillage when transporting or during temporary storage, the generator should be secured upright in its normal operating position, with engine switch off.

## WARNING

When transporting generator:

Do not overfill the tank (there should be no fuel in the filler neck).

Do not operate the generator while it is on a vehicle.

Take the generator off the vehicle and use it in a well ventilated place.

Avoid a place exposed to direct sunlight when putting the generator on a vehicle. If the generator is left in an enclosed vehicle for many hours, high temperature inside the vehicle could cause fuel to vaporize resulting in a possible explosion.

Do not drive on a rough road for an extended period with the generator on board. If you must transport the generator on a rough road, drain the fuel from the generator beforehand.

Before storing the unit for an extended period:

1. Be sure the storage area is free of excessive humidity and dust.
2. Drain the fuel
  - a. Drain all gasoline from the fuel tank into an approved gasoline container.
  - b. Turn the fuel cock ON, and loosen the carburetor drain screw and drain the gasoline from the carburetor into a suitable container.
  - c. With the drain screw loosened remove the spark plug cap, and pull the starter grip 3 to 4 times to drain the gasoline from the fuel pump.
  - d. Turn the fuel cock to the OFF position, and tighten the carburetor drain screw securely.
  - e. Reinstall the spark plug cap on the spark plug securely.

## WARNING

Gasoline is extremely flammable and explosive under certain conditions.

Do not smoke or allow flames or sparks in the area.

# TRANSPORTING/STORAGE

---

3. Change the engine oil.
4. Remove the spark plug and pour about a tablespoon of clean engine oil into the cylinder. Crank the engine several revolutions to distribute the oil, then reinstall the spark plug.
5. Slowly pull the starter grip until resistance is felt. At this point, the position is coming up on its compression stroke and both the intake and exhaust valves are closed. Storing the engine in this position will help to protect it from internal corrosion.

OWNER'S MANUAL GI2000SX Revision English

MOSA Divisione della BCS S. p. A.  
Viale Europa, 59 20090 CUSAGO (MI)  
Italy

Internet: [www.mosa.it](http://www.mosa.it)